

# Voyager Solid

THORN

96634938 VOYAGER SOLID L P MS HP E3D WH

|                           |      |      |    |                         |  |
|---------------------------|------|------|----|-------------------------|--|
| IEC EN<br>60598-1<br>RG 1 | IP65 | IK07 | CE | T <sub>a</sub> 0<br>+35 |  |
|---------------------------|------|------|----|-------------------------|--|

## Voyager Solid

IP65 LED safety luminaire for surface ceiling mounting; semi-recessed mounting possible with optional mounting frame; luminaire with local battery supply for 3h emergency lighting; display of luminaire status via status LED; automatic test via luminaire, optional central luminaire monitoring via DALI line; settable emergency light level; non-maintained and maintained mode settable via jumper and NFC; addressing alternatively possible visually or via EZ-addressing; cable length from emergency power source to last luminaire: 300 m; housing made of polycarbonate white; cover made of transparent polycarbonate; tool-less 'click' mounting after fitting the housing base; quick fit terminal block, through wiring possible up to 2,5 mm<sup>2</sup>; zero maintenance thanks to LED technology; service life of 50,000 h; rated supply voltage: 220/240 V; luminaire input power: max. 12 W; degree of protection: IP65; class of protection: SC2; impact strength: IK07; dimensions: 360 x 71 x 150 mm; weight: 1.45 kg

Self-contained emergency luminaires rely on long-lasting batteries. Thorn batteries are robust and comes with a three-year guarantee (applicable subject to the terms and conditions of and to the extent as set forth in the manufacturer's guarantee on Thorn products, which shall be applicable analogously and which is available under [http://www.thornlighting.com/en/products/5-year-guarantee/5-year-warranty/terms-of-guarantee\\_en.pdf](http://www.thornlighting.com/en/products/5-year-guarantee/5-year-warranty/terms-of-guarantee_en.pdf). The battery guarantee shall not come into effect if the product has been installed later than three(3) months after delivery EXW (Incoterms 2010).



TLG\_VYSO\_F\_OPL.jpg

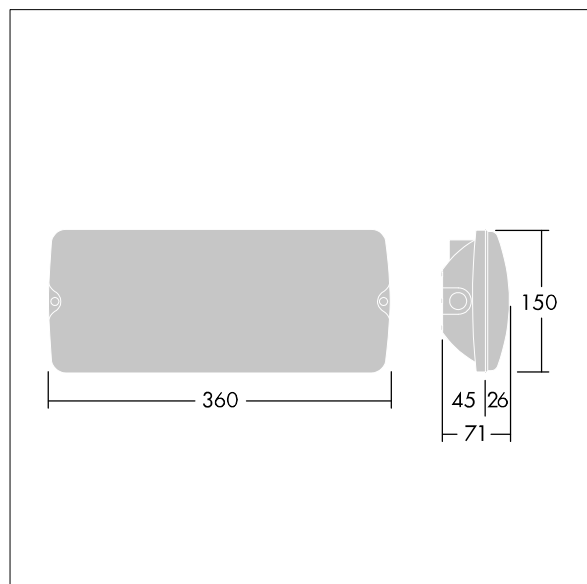

TLG\_VYSO\_M\_LDL.wmf

All values marked with an \* are rated values. Thorn uses tried and tested components from leading suppliers, however there may be isolated instances of technology-related failures of individual LEDs during the rated product lifetime. International standards set the tolerance in initial flux and connected load at ±10%. Unless stated otherwise, the values apply to an ambient temperature of 25°C.

Thorn Lighting is constantly developing and improving its products. The right is reserved to change specifications without prior notification or public announcement.  
© Thorn Lighting